



## GENERAL

### ALPD Positive Displacement Gear Flow Meters

The SMC series ALGPD Gear flow meter is suitable for the precise flow measurement of fluids with viscosities ranging from 5 to 25,000 cSt. Providing sufficient lubricity of the fluid, the small gear flow meters type ALGPD 01/1 and 02, as well as ball bearing versions may be used for fluids below 5 cSt. Gear flow meters are positive displacement meters, similar in design to a gear pump. The measuring medium rotates two gears, which are engaged with minimum play. The medium is forced along through closed measuring chambers between the gears and housing. The gears, which run idle, lose no power. The RPM of the gears is in direct proportion with the instantaneous flow rate and is precisely detected by integral pickups through the body of the meter without contacting the fluid. The flow signal can be displayed using our ALVTM or our various other electronics. We calibrate our flow meters with K factors that are tailored to our customers' operating viscosities.

### ALVTM Display with Frequency and Analog Output

The ALVTM is a programmable local display with integral carrier frequency pickoff and amplifier for SMC turbine and PD-type meters. Flow rate is indicated by an 8 digit LCD display with 14 segments. A 10-point linearization is included to optimize the accuracy. The pulse output provides a flow-proportional frequency signal or scaled volume pulse in accordance with the user's programming. The electrical connection consists of either a 6-pin plug or a junction box with an internal 6-position terminal block.

## FEATURES

- High output frequencies resulting in good resolution suitable for pulsating flows.
- Reverse-flow detection and pulse multiplication functions
- Ex-protection EExIICT6/T4
- Resistance to high voltage from 50 kV up to 120 kV
- Special meters with high-pressure connectors up to 10,000 psig (690 bar).
- Heated versions are available on request.
- The K-factor (volume per pulse) is almost constant over a wide range.



## SPECIFICATION

### Gear Flowmeters ALGPD - series

- Connections : Female for, Ermeto-fittings GE 6-PSM, GE 14-PSM or GE 25-PSM, bores for SAE flanges 1¼"
- Operating pressure : small size up to 10,000 psi bar, larger to 55,00
- Process temperature : 355 °F (180 °C)
- Flow rates : 0.001-265 GPM (0.005 to 1000 LPM)
- Viscosities : 5 up to 25,000 cSt
- Material :  
Housing : SS per DIN 1.4305/AISI 303 or 1.4571/AISI 316 Ti  
Gears : SS as per DIN 1.4122/AISI 303 or 1.4460/AISI 329  
Shafts, bearing bushes, tungsten carbide, ball bearings  
Seals : O-rings: viton, teflon, NBR or EPDM (for brake fluid)
- Linearity : ±0.5% of value @ 1:20 for viscosity 15 -50 cSt  
±0.25% of value for viscosities 50 to 25,000 cSt
- Weight : 0.8-8.8 lbs (0.4 to 4 kg)

### ALVTE Carrier Frequency Pulse Amplifier

- Supply Voltage  $V_B$  : +8.5 up to 29  $V_{DC}$ , regulated.  
(incl. reverse-battery protection)
- Quiescent current : < 5 mA
- Frequency range : 2 up to 4,000 Hz
- Process temperature : 250 °F (120 °C) with a distance of at least 1" (25 mm) between flow meter and electronic housing; 300 °F (150 °C) with a distance of at least ½" (65 mm)

### ALVTM Electronics

- LCD display : 8 digits (14 segments), digit height 7mm for real-time value, totals and programmable
- Linearization : with 10 points
- Process temperature : -40 - 250 °F (-40 - 120 °C) with a distance of at least 1" (25 mm) between flow meter and electronic housing
- Ambient temperature : -40 up to 160 °F (-40 - 70 °C)
- Weight : 1.5 lbs (700 g)
- Frequency output/divider :  
3-wire, 8-30  $V_{DC}$  controlled, Ex-versions : 12-30  $V_{DC}$ , < 25 mA, signal output, push/pull,  $I_{max}$ : 20mA, frequency output,  $f_{max}$ : 3,000Hz, duty cycle: approximately 50%, pulse width: 1 ms, 20 ms, 50 ms,  $f_{max}$ : 500 Hz
- Analog output : 2-wire (4-20mA)
- Supply voltage : 14-30 $V_{DC}$  controlled,  $V_B=(R_{load} \times 20 \text{ mA})+ 14V$
- Load : ≤ 800 Ω
- Time constant : < 0.2-3 s (programmable)
- Resolution : 12 bit (3.9μA)
- Housing : IP 65, aluminum AlMgSiPb, blue anodized
- Ex-protection : II 2 G EEx ia IIC T4, BVS 03 ATEX E 205

Also see SMC flow computer

### SmartMeasurement.

10437 Innovation Drive, Milwaukee, WI 53226, USA

TEL: +1-866-404-5415 FAX: +1-414-433-1606

Pressure Drop

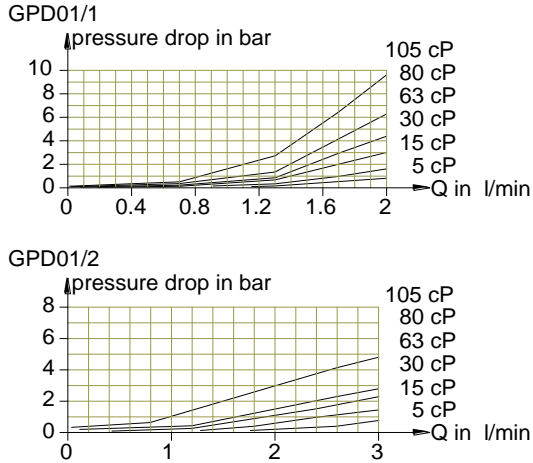

Pressure Drop

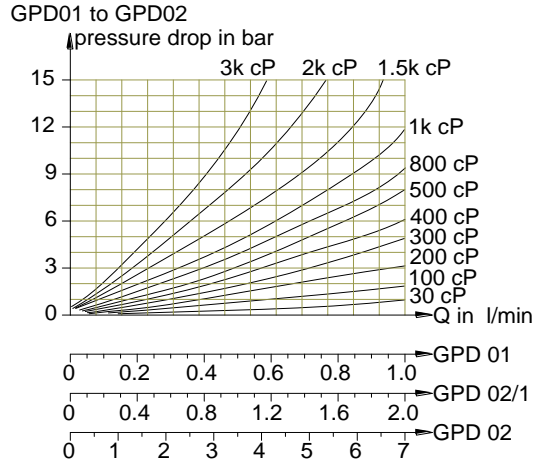

Pressure Drop

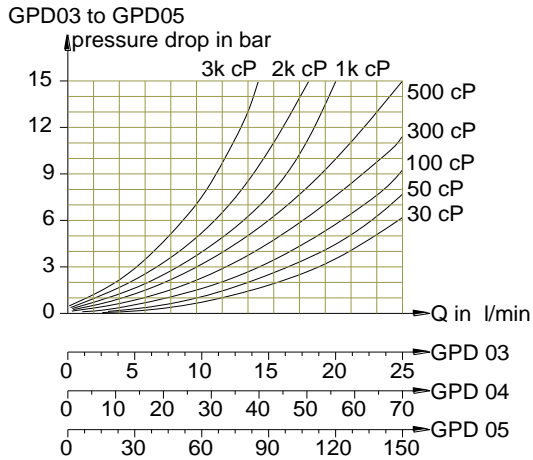

Pressure Drop

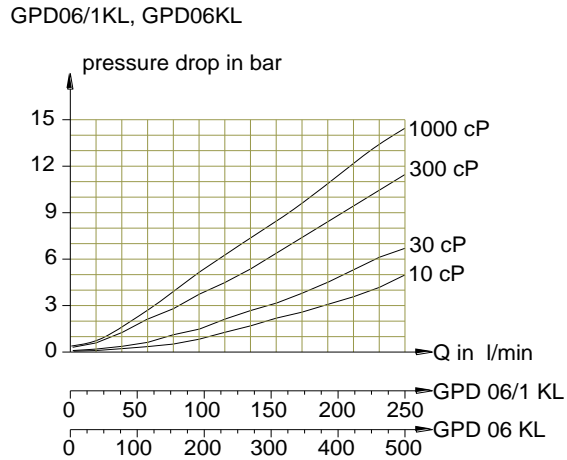

Pressure Drop

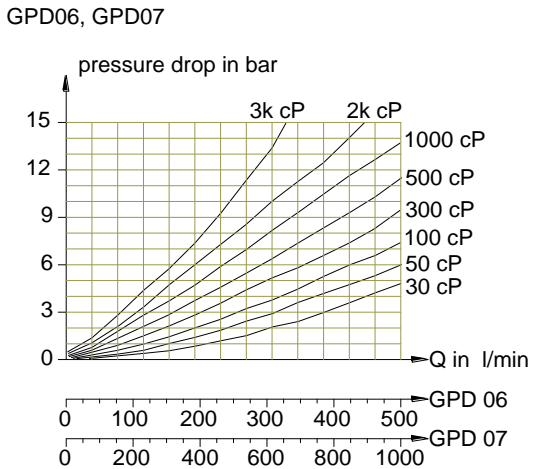

K-Factors at different viscosities

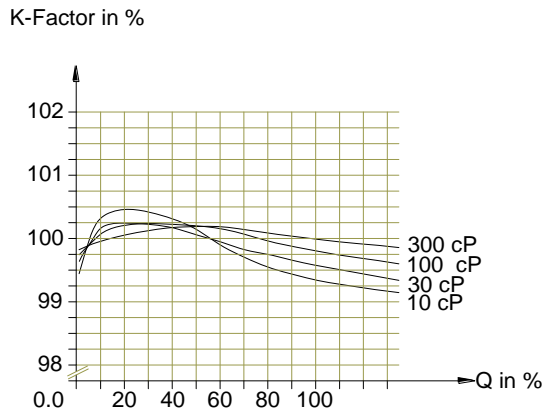

Dimensional drawings (mm)

GPD01 to GPD05

Side view

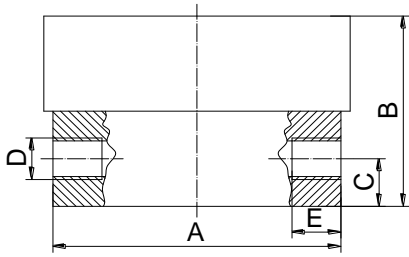

Bottom view

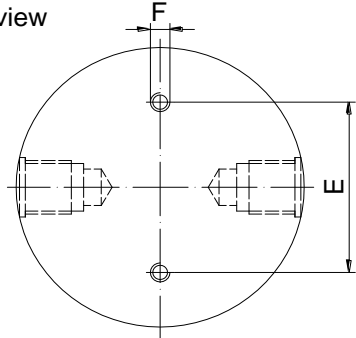

metric threads

Type	A $\Phi$	B	C	D	E
GPD01	72	21	10.5	M12×1.5	14
GPD01/1	72	21	10.5	M12×1.5	14
GPD01/2	72	30	10.5	M12×1.5	14
GPD02/1	80.5	26	12	M12×1.5	14
GPD02	80.5	30	12	M12×1.5	14
GPD03	80.5	42	12	M12×1.5	14
GPD04	121	34	17	M20×1.5	18
GPD05	170	45	22.5	M33×2	18

Type	E	F
GPD01	44	M6
GPD01/1	44	M6
GPD01/2	44	M6
GPD02/1	44	M6
GPD02	44	M6
GPD03	44	M6
GPD04	60	M6
GPD05	100	M8

GPD06 to GPD07

Side view

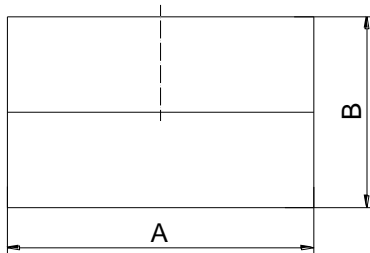

Bottom view GPD06

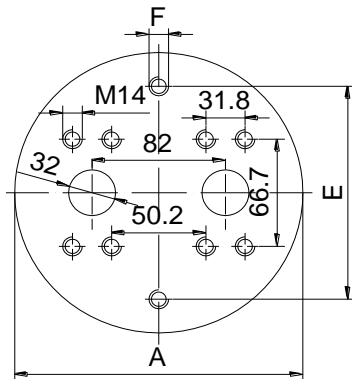

Type	A	E	F
------	---	---	---

GPD06/1 KL	188	142	M12
GPD06 KL	188	142	M12
GPD06	188	142	M12

Connections only for bottom entry.

metric threads

Type	A	B
GPD06/1 KL	188	138
GPD06 KL	188	180
GPD06	188	180
GPD07 KL	232	200
GPD07	232	220

Bottom view GPD07

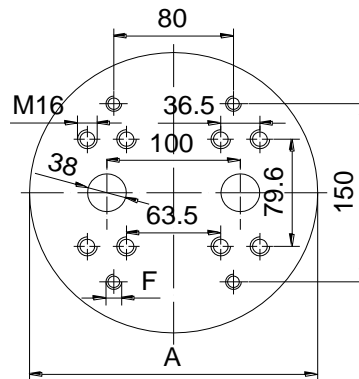

Type	A	F
------	---	---

GPD07	232	M12
-------	-----	-----

Connections only for bottom entry.

**\*\* Please contact your local SMC application engineer**

**You also need to provide the following information:**

Type of liquid	We need the name of your liquid, including operating density and viscosity
Full Scale Flow	Note the flow ranges below
Line Size	we need to know your pipe size as well connection type (flange, threaded, etc..)
Process Pressure and Temperature	Please note our pressure and temperature limits
Density and Viscosity	You can substitute Specific Gravity (SG) for density
Type of Electronics	Indicate if you want integral, remote panel or remote wall mounted
Power Requirements	Specify your power requirements such as 24 V <sub>DC</sub> or 115 V <sub>AC</sub> or 230 V <sub>AC</sub>

## Model Selection Guide

ALGPD Series					
Example ALGPD-02/1-ST-ALVTMB-F-EX					
ALGPD Series	XXX				Description
female threads for Ermeto-fittings GE 6-PSM	01	0.005 to 1			Sizes and Flow rates (LPM)
female threads for Ermeto-fittings GE 6-PSM	01/1	0.005 to 2			
female threads for Ermeto-fittings GE 6-PSM	01/2	0.02 to 3			
female threads for Ermeto-fittings GE 6-PSM	02/1	0.05 to 2			
female threads for Ermeto-fittings GE 6-PSM	02	0.1 to 7			
female threads for Ermeto-fittings GE 6-PSM	03	0.5 to 25			
female threads for Ermeto-fittings GE 14-PSM	04	0.5 to 70			
female threads for Ermeto-fittings GE 25-PSM	05	5 to 150			
bores for SAE flanges 1 1/4"	06/1	5 to 250			
bores for SAE flanges 1 1/4"	06	20 to 500			
bores for SAE flanges 1 1/4"	07	50 to 1000			
Hard metal bearing	ST				Bearings, construction
ball bearing	KL				
Ball bearing & Aluminum body	KLA				
Cartridge Desing only 01 size	STCT				
Light Weight-stainless steel only 02 size	STLW				
Electronics - ALVTM (programable display) series					
Frequency/divider and analog	ALVTMB				Analog output
Top View		D			display arrangement
Standard with window		NX			Protection
Ex proof with window		EX			
Electronics - ALVTE Carrier Frequency Pulse Amplifier					
Carrier-Frequency pickup	ALVTE				frequency range 2-4000 Hz
Standard		NX			Protection
Ex proof		EX			
Short thread 110 mm		EK			Thread size
Long thread 149 mm		EL			
Electronics - ALIF-Inductive Pickups and Pulse Amplifiers (for -12 to 180C)					
Frequency pulse amplifier	ALIF				
Standard		NX			Protection (II 2 G EEx ia IIC T6)
Ex proof		EX			

### Meter specification and K factor

Type	Flow (LPM)	K-factor* pulses/ltr.		Frequency range 0 to max (in Hz)	
01	0.005 to 1	41000	82000	3.4	683
01/1	0.005 to 2	26500	53000	2.2	883
01/2	0.02 to 3	14000	28000	4.6	700
02/1	0.05 to 2	8200	16400	6.8	273
02	0.1 to 7	4200	8400	7	490
03	0.5 to 25	1740	3480	14	725
04	0.5 to 70	475	950	4	554
05	5 to 150	134	268	11	335
06/1	5 to 250	106	212	8.8	442
06	20 to 500	53	106	18	442
07	50 to 1000	24	48	20	400