



GENERAL

ALHPD Positive Displacement Helical Flow Meters

Two highly accurate cycloid-shaped screw spindles mesh and rotate inside a cylindrical housing with two overlapping holes in the form of a figure 8, which forms the measuring chamber. Liquid flows in axial direction and rotates the spindles; it is forced along the measuring chamber bores by the profile of the spindles. This occurs without pulsation and with minimum leakage. An inductive pickoff will detect the speed of the spindle pair through the housing via a pole wheel with a high number of gears. The speed of the spindles is directly proportional to the volumetric flow rate over a very wide range. This sensor will output a highly accurate pulse train or an analogue 4-20 mA signal when used in conjunction with the ALVTM local display unit. All units come factory calibrated under conditions that match the end user's operating viscosity as closely as possible in order to determine the optimal K-factor (pulses per unit volume).

ALVTM Display with Frequency and Analog Output

The ALVTM is a programmable local display module with integrated carrier-frequency pickup and amplifier for SMC turbine and positive displacement meters. Flow rate is indicated in an 8 digit, 14 segment LCD display. A 10 point linearization scheme is included to optimize the accuracy. The pulse output provides a flow-proportional frequency signal or scaled volume pulse in accordance with user programming. For electrical connections, a 6-pin plug or a junction box with 6 internal terminals is provided.

FEATURES

- High accuracy and wide turndown ratios; up to 400:1
- Suitable for pressures up to 5800 psig (400 bar)
- Low pressure drop versus other style of positive displacement meters
- Double pulse rate and reverse-flow detection possible
- Pulsation-free measurement, readings unaffected by pulsating flows
- High quality materials and bearings provide superior corrosion resistance
- Low operating noise
- Ex-protection EExia IIC T6 for zone 1



SPECIFICATION

ALHPD- Helical Flow Meters

- Process connections: ½"-1½" FNPT
- Operating pressure : 5800 psig (400 bar) max.
- Process temperature: up to 300°F (150°C); higher upon request
- Flow rates : 0.002 to 105 GPM (0.01 to 400 LPM)
- Viscosities : 30 up to 1,000,000 cSt (below 30 cSt with restricted measuring range and vertical mounting)
- Material : SS DIN 1.4571/1.4435 (SS316 Ti/316L)
- Linearity : ±0.50% of actual flow value (from 30 mm²/s up) ±0.25% of actual flow value (from 100 mm²/s up)
- Repeatability : ±0.10%
- Weight : Flowmeters : 2.5 to 35 kg
Electronics : 0.25 kg to 2.5 kg

ALVTE Carrier Frequency Pulse Amplifier

- Supply Voltage V_B : +8.5 up to 29 V_{DC} , regulated (incl. reverse-battery protection)
- Quiescent current : < 5 mA
- Frequency range : 2 up to 4,000 Hz
- Process temperature : 250 °F with a distance of at least 1" between flowmeter and electronic housing; 300 °F w/ at least 2½"

ALVTM Electronics

- LCD display : 8 digits (14 segments), digit height ¼" (7mm) for real-time value, totals and programmable
- Linearization : with 10 points
- Process temperature : -40~ 248 °F (-40~120 °C) w/ a distance of ≥ ½" (25 mm) between flowmeter and electronics
- Ambient temperature : -40 up to 158 °F (-40 up to 70 °C)
- Weight : 1½ lbs (700 g)
- Frequency output/divider : 3-wire, 8-30 V_{DC} controlled, Ex-versions: <25 mA, 12-30 V_{DC}
- Signal output : push/pull, I_{max} : 20 mA,
- Frequency output, fmax: 3,000 Hz, duty cycle: approx. 1:1, 2:1 divider, pulse width: 1 ms, 20 ms, 50 ms, fmax: 500 Hz
- Analog output : 2-wire (4-20mA)
- Supply voltage : 14-30 V_{DC} controlled, $V_B = (R_{load} \times 20 \text{ mA}) + 14 \text{ V}$
- Load : < 800 Ω
- Time constant : < 0.2-3 s (programmable)
- Resolution : 12 bit (3.9 μA)
- Housing : IP 65, aluminum AlMgSiPb, blue anodized
- Ex-protection : II 2 G EEx ia IIC T4, BVS 03 ATEX E 205

SmartMeasurement

10437 Innovation Drive, Suite 315, Milwaukee, WI 53226, USA

TEL+1-866-404-5415 FAX+1-414-433-1606

Pressure Drop Diagram

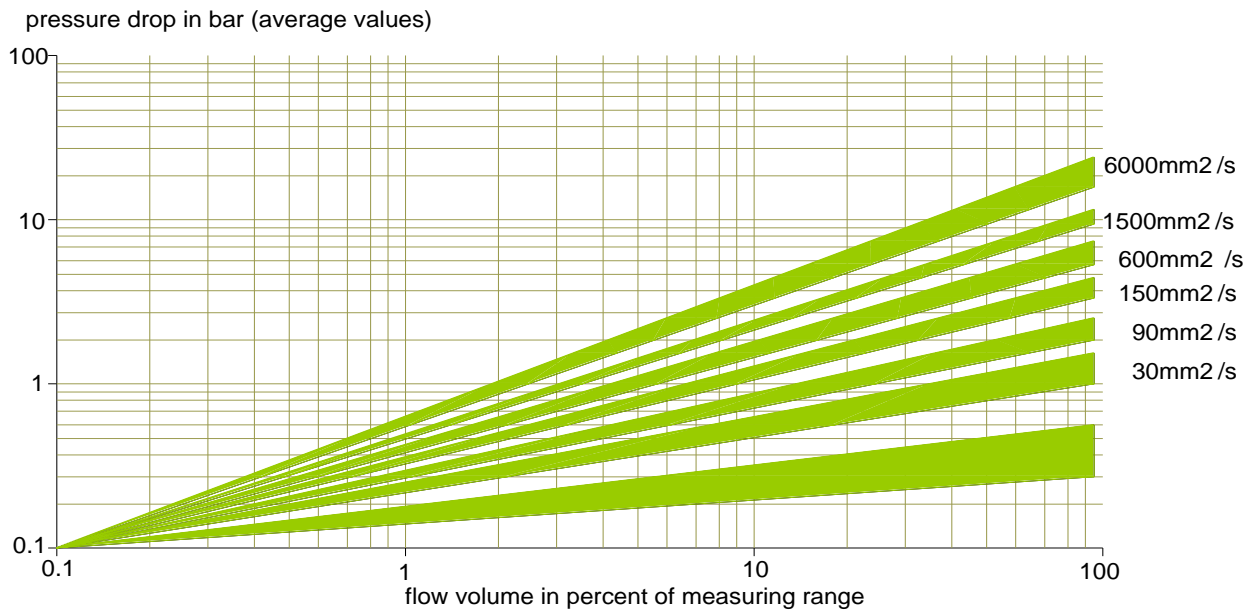

K- Factor for Positive Displacement Helical Flow Meters

Type	Flow (GPM)	K-factor (pulses/gal)	Frequency range in Hz.	
			Min	Max
ALHPD				
HPD 10	0.01 to 0.1 and 0.1 to 1	62453	3	1000
HPD 20	0.04 to 0.4 and 0.4 to 4.0	34065	6	1250
HPD 40	0.1 to 1.0 and 1.0 to 10	13248	20	1740
HPD 100	0.25 to 2.5 and 2.5 to 25	3217	8	1750
HPD 4000	1.0 to 10.0 and 10.0 to 100	810	14	1800

Cross Section Drawings

HPD10

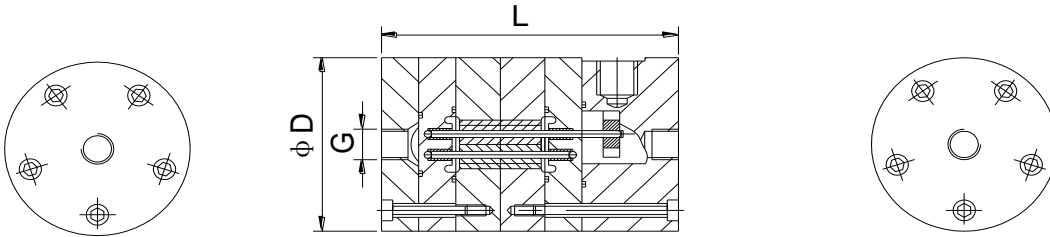

HPD20

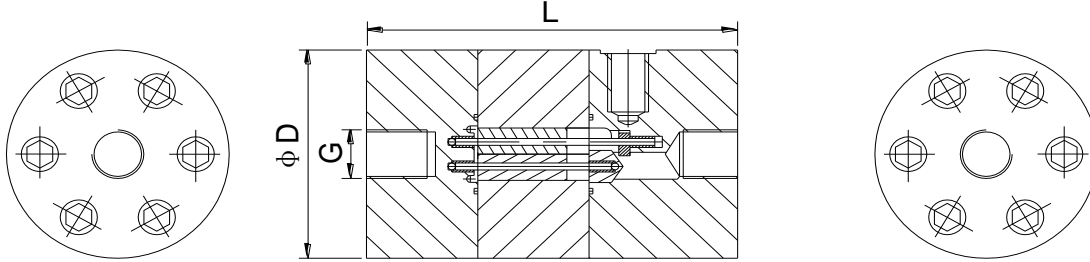

HPD40/HPD100/HPD400

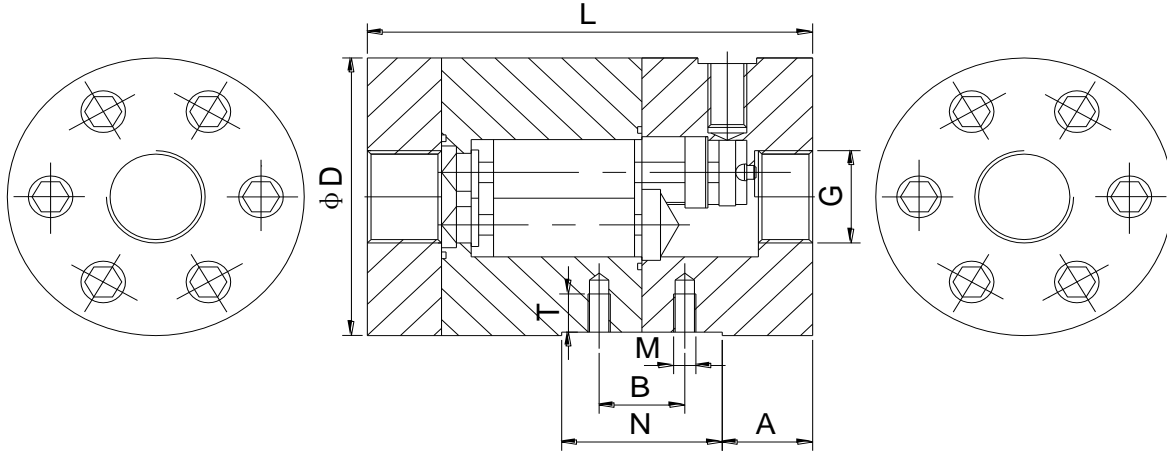

Dimensions

Type	G	L	D	PN
HPD10	1/4"	110mm	60mm	400bar
HPD20	1/2"	125mm	76mm	400bar
HPD40	3/4"	155mm	85mm	400bar
HPD100	1"	221mm	110mm	400bar
HPD400	1 1/2"	318mm	134mm	400bar

Fixing holes(only HPD40 and 100)

Type	M	T	B	N	A
HPD40	M8	12.0mm	25.4mm	52.0mm	36.5mm
HPD100	M10	18.0mm	44.0mm	66.0mm	54.0mm

**** Please contact your local SMC application engineer**

You also need to provide the following information:

Type of liquid	Please provide the name of your liquid, including operating density and viscosity
Full Scale Flow	Please specify your maximum and minimum flow rates, units must be Kg/hr, Lb/hr, LPM or GPM
Line Size	Please indicate pipe size as well connection type (flange, threaded, etc..)
Process Pressure and Temperature	We will calibrate your flowmeter as close to your operating conditons as possible
Pressure drop	Please specify your process' maximum allowable pressure drop (see pressure drop graph)
Type of Electronics	Indicate if you want integral, remote panel or remote wall mounted electronics
Power Requirements	Specify your power requirements such as 24 V _{DC} or 115 V _{AC} or 230 V _{AC}

Model Selection Guide

ALHPD Series			
Example ALHPD-100-ST-ALVTMB-F-EX			
ALHPD Series	***		Description
1/4 inch	10	0.01 to 0.1 and 0.1 to 1	Sizes and Flow rates (LPM)
1/2 inch	20	0.04 to 0.4 and 0.4 to 4.0	
3/4 inch	40	0.1 to 1.0 and 1.0 to 10	
1 inch	100	0.25 to 2.5 and 2.5 to 25	
1 1/2 inch	400	1.0 to 10.0 and 10.0 to 100	
Hard metal bearing	ST		Bearings
ball bearing	KL		
Compact with integral dual pickup		C	Only available from ¼" to 1½" size
Electronic Options - IF no electronics leave parts below blank (part number for electronics depends on ALVTMB,ALVTE or ALIF)			
Electronics - ALVTM (programmable display) series			
Frequency/divider and analog	ALVTMB		Analog outputs
Top View		D	Display
Standard with window		NX	Protection
Ex proof with window		EX	
Electronics - ALVTE Carrier Frequency Pulse Amplifier			
Carrier-Frequency pickup	ALVTE		frequency range 2-4000 Hz
Standard		NX	Protection
Ex proof		EX	
Short thread 110 mm		EK	Thread size
Long thread 149 mm		EL	
Electronics - ALIF-Inductive Pickups and Pulse Amplifiers (for -12 to 180C)			
Frequency pulse amplifier	ALIF		
Standard		NX	Protection (II 2 G EEx ia IIC T6)
Ex proof		EX	