



GENERAL

The innovative SMC 9000 ATMF Series inline mass flowmeter features **Flow Averaging Tubes (FAT™)** that will provide a stable flow signal even in non-ideal flow profiles, such as downstream of a bend, elbow, valve, tee or any other obstruction. The flow averaging tube has a number of large (1/8") inlet ports along the length of the upstream impact surface. The impact pressure at each inlet port is averaged inside the tube to create the axial flow through the tube and across the flow sensor. The gas flow then passes back into the main flow stream through the gas return

located near the flow sensing elements. The Inline Series 9000 ATMF also includes built in flow conditioners for stable performance at 3 diameters downstream of an obstruction.

FEATURES

- Direct mass flow measurement of any gas with actual gas calibration
- Ideal for flow profiles of less than three diameter upstream
- Up to four independent, switchable flow curves
- Tracking of overall gas consumption over a turndown ratio of at least 100:1
- Data logger that can store flow, velocity, temperature, and total
- A 2 line, 16 character display for rate, total, and relay status
- User selectable engineering units, dynamically converts the flow rate and total flow
- Available with infrared communicator for remote access of data
- Standard software available multi-curve fit programs
- Up to 20 instantaneous flow adjustments

SPECIFICATIONS

- | | | | | | | | | | | | | | | | | | | | | | | | | | | | | | |
|--|---|-----------------|--|----------|----------------|----------|----------------|----------|-----------------|----------|----------------|----------|----------------|--------------|--------------------------------------|---------------|--|----------|----------------|----------|-----------------|----------|----------------|----------|-------------|----------|-----------------|--------------|-------------------------------------|
| <ul style="list-style-type: none"> ● Process Connections: Threaded, Flanged ● Process temperature : 32 - 392 °F (0 - 200 °C) ● Operating pressure : 580 psi (40 bar) ● Mass Flow rate : See model selection guide section ● Flow units : Kg/hr, Kg/mn, Kg/s Lb/hr, Lb/m Lb/s NCMH, SCFM, NLPM, SLPM Mt/s, F/mn, BTU/Hr, BTU/min ● Gas pressure effect : Minor, under ±20% of calibration pressure ● Gas temperature effect : 0.01% /° C ● Accuracy (and linearity) : ± [1% of Reading + (.5% FS+ .02%/°C)] ± 0.2% of Full Scale ● Repeatability : ± 0.25% of Full Scale ● Turn down ratio : Over 100:1 ● Response time : Less than one seconds ● Material : 316SS as per DIN 1.4571 (AISI 316 Ti) ● Data logger : Flow rate, Total, Relays, etc. 5800 data ● Linear signal output : 0-5 V_{DC} & 4-20 mA ● Pulse output : scalable ● Relays : Two 1-amp, SPDT (form C) User-selectable alarm functions ● Display units : Flow, Total flow, Switch settings Temperature, Elapsed time ● RAM Back-up : Lithium Battery ● Data storage : EPROM storage up to 10 years ● Self diagnostics functions : ADC, DAC, alarm for EMI interference | <ul style="list-style-type: none"> ● Housing protection : NEMA 4, Class 1, Div 1, Groups B, C, D ● Ex-protection : II 2 GD EEx d IIC T2 or T3 or T4 <div style="text-align: center;"> </div> <ul style="list-style-type: none"> ● Cable (remote version) : 985' (300 meters) ● Wetted materials : 316 SSS (Hastelloy and Monel optional) ● weight (approximate) : <table border="0" style="margin-left: 20px;"> <tr><td>Integral Type :</td><td></td></tr> <tr><td>9716MP :</td><td>17½ lbs (8 KG)</td></tr> <tr><td>9720MP :</td><td>22 lbs (10 KG)</td></tr> <tr><td>9724MP :</td><td>26½ lbs (12 KG)</td></tr> <tr><td>9732MP :</td><td>33 lbs (15 KG)</td></tr> <tr><td>9748MP :</td><td>44 lbs (20 KG)</td></tr> <tr><td>MPNH style :</td><td>less by 1 lb (0.5 kg) for each above</td></tr> <tr><td>Remote Type :</td><td></td></tr> <tr><td>9116MP :</td><td>22 lbs (10 KG)</td></tr> <tr><td>9120MP :</td><td>26½ lbs (12 KG)</td></tr> <tr><td>9124MP :</td><td>31 lbs (14 KG)</td></tr> <tr><td>9132MP :</td><td>37½ (17 KG)</td></tr> <tr><td>9148MP :</td><td>48½ lbs (22 KG)</td></tr> <tr><td>MPNH style :</td><td>less by 2 lbs (1 kg) for each above</td></tr> </table> Notes : -weight 150# flanges included (2 lbs for 300#) ● Signal Interface : RS232 & RS485, HART, MODBUS, etc.. ● Power requirements : 115V_{AC} @, ½ A 230V_{AC} @ ¼ A 24 V_{DC} @ ¼ A ● Power Consumption : 5 Watts or less ● NIST traceable : Standard for all calibration | Integral Type : | | 9716MP : | 17½ lbs (8 KG) | 9720MP : | 22 lbs (10 KG) | 9724MP : | 26½ lbs (12 KG) | 9732MP : | 33 lbs (15 KG) | 9748MP : | 44 lbs (20 KG) | MPNH style : | less by 1 lb (0.5 kg) for each above | Remote Type : | | 9116MP : | 22 lbs (10 KG) | 9120MP : | 26½ lbs (12 KG) | 9124MP : | 31 lbs (14 KG) | 9132MP : | 37½ (17 KG) | 9148MP : | 48½ lbs (22 KG) | MPNH style : | less by 2 lbs (1 kg) for each above |
| Integral Type : | | | | | | | | | | | | | | | | | | | | | | | | | | | | | |
| 9716MP : | 17½ lbs (8 KG) | | | | | | | | | | | | | | | | | | | | | | | | | | | | |
| 9720MP : | 22 lbs (10 KG) | | | | | | | | | | | | | | | | | | | | | | | | | | | | |
| 9724MP : | 26½ lbs (12 KG) | | | | | | | | | | | | | | | | | | | | | | | | | | | | |
| 9732MP : | 33 lbs (15 KG) | | | | | | | | | | | | | | | | | | | | | | | | | | | | |
| 9748MP : | 44 lbs (20 KG) | | | | | | | | | | | | | | | | | | | | | | | | | | | | |
| MPNH style : | less by 1 lb (0.5 kg) for each above | | | | | | | | | | | | | | | | | | | | | | | | | | | | |
| Remote Type : | | | | | | | | | | | | | | | | | | | | | | | | | | | | | |
| 9116MP : | 22 lbs (10 KG) | | | | | | | | | | | | | | | | | | | | | | | | | | | | |
| 9120MP : | 26½ lbs (12 KG) | | | | | | | | | | | | | | | | | | | | | | | | | | | | |
| 9124MP : | 31 lbs (14 KG) | | | | | | | | | | | | | | | | | | | | | | | | | | | | |
| 9132MP : | 37½ (17 KG) | | | | | | | | | | | | | | | | | | | | | | | | | | | | |
| 9148MP : | 48½ lbs (22 KG) | | | | | | | | | | | | | | | | | | | | | | | | | | | | |
| MPNH style : | less by 2 lbs (1 kg) for each above | | | | | | | | | | | | | | | | | | | | | | | | | | | | |



The SMC Advantage

SMC ATMF 9000 Series inline flowmeters significantly reduce the requirements for straight, unobstructed upstream piping. Depending upon the piping configuration, the traditionally required upstream straight run can be 10, 20, or even 50 diameters (see installation diagram below for recommended piping for standard flowmeters).

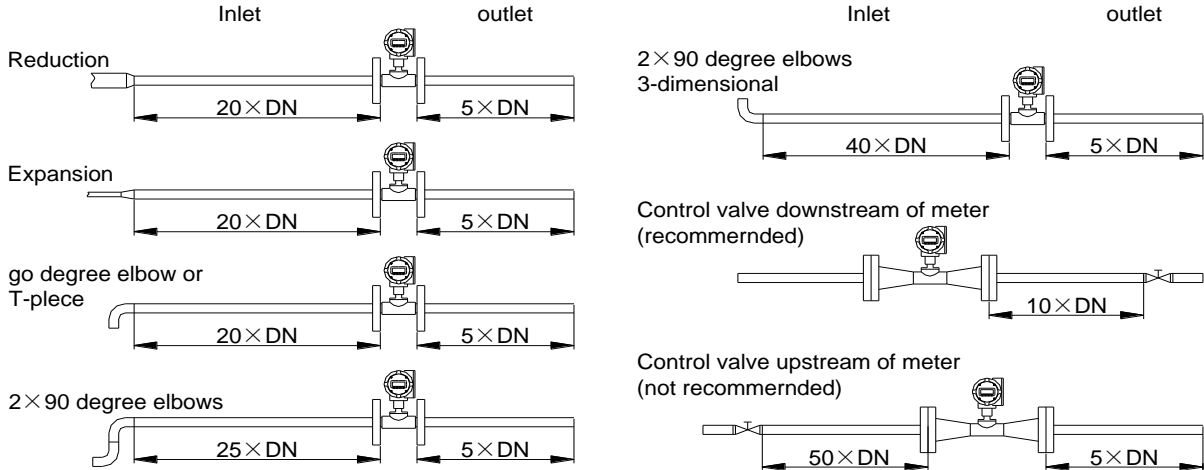

General recommendation of piping for typical insertion and inline flow meters

By measuring the flow velocities across the pipe, the 9000 series is far more tolerant of flow profile problems than any other mass flow device on the market. This allows the required straight run to be dramatically reduced. The upstream requirement can be reduced to as little as three diameters.

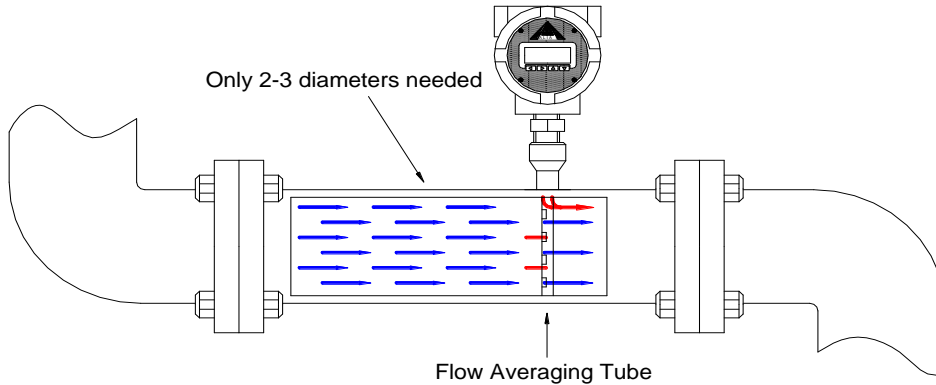

Typical Inline FAT Pressure Drop

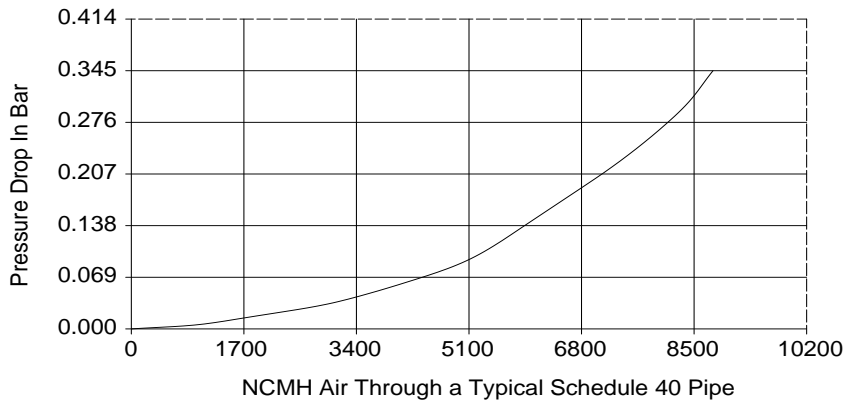

ATMF 9000 Inline Flowmeter - Remote Version

Hazardous Version

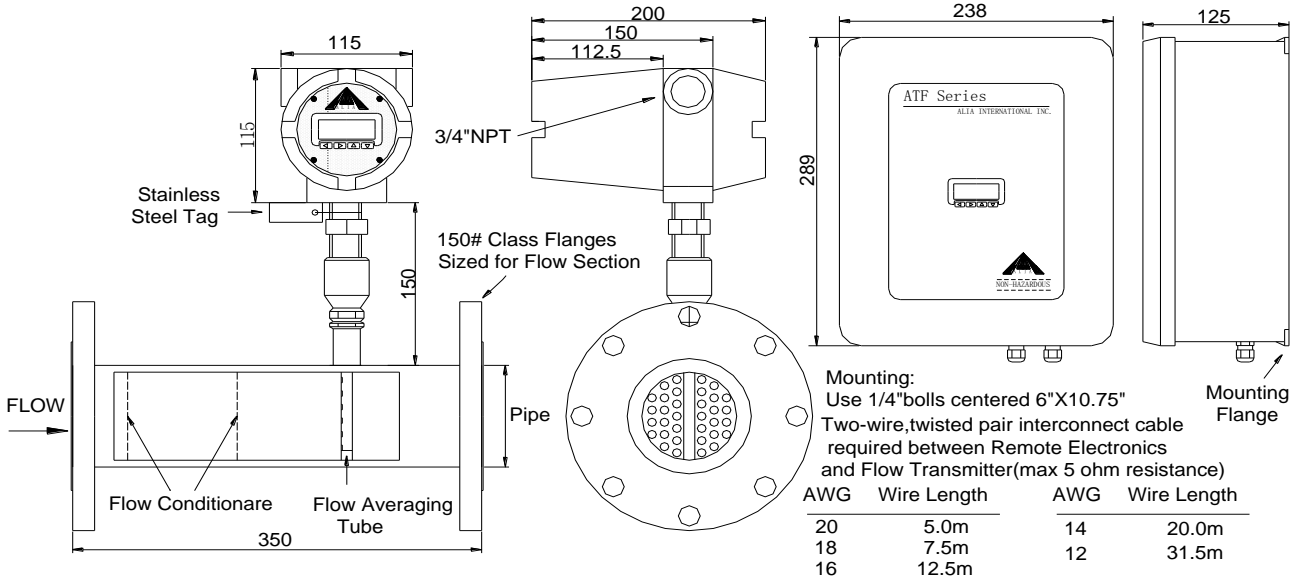

Non-hazardous Version

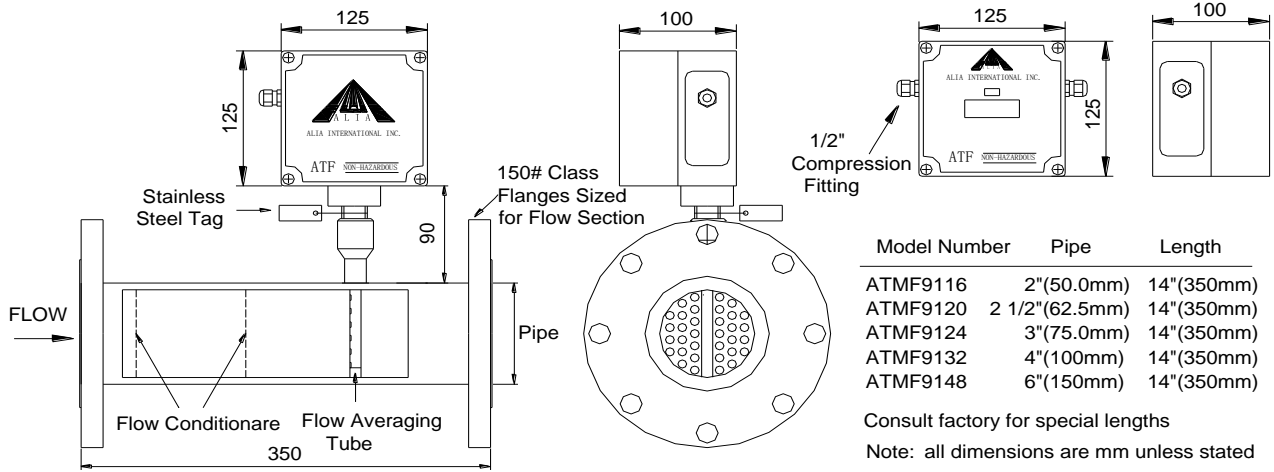

ATMF 9000 Inline Flowmeter - Integral Version

Non-hazardous Version

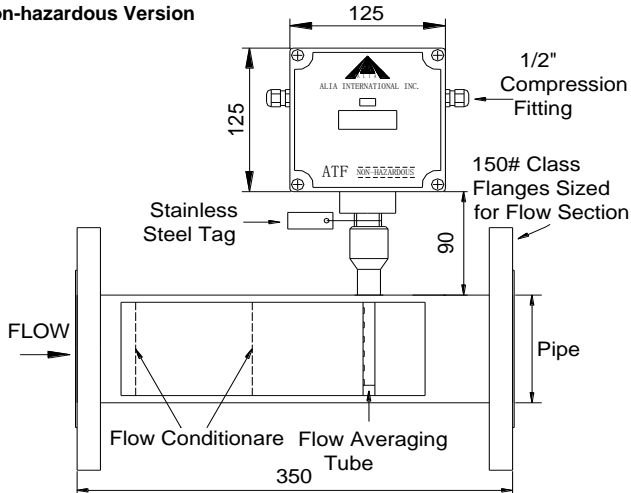

Model Number	Pipe	Length
ATMF9716	2" (50.0mm)	14" (350mm)
ATMF9720	2 1/2" (62.5mm)	14" (350mm)
ATMF9724	3" (75.0mm)	14" (350mm)

Hazardous Version

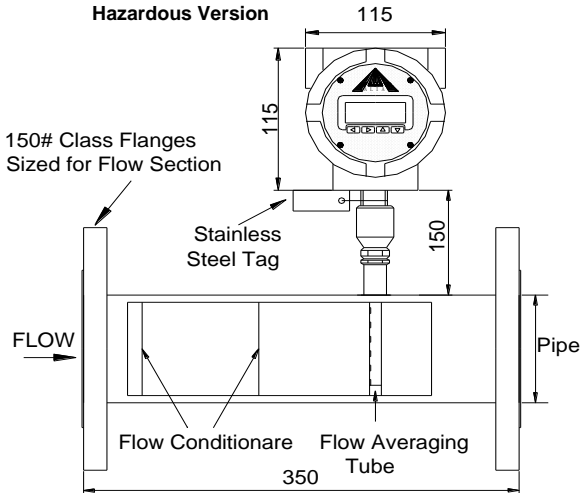

Model Number	Pipe	Length
ATMF9732	4" (100.0mm)	14" (350mm)
ATMF9748	6" (150.0mm)	14" (350mm)

Consult factory for special lengths
Note: all dimensions are mm unless stated

**** Please contact your local SMC application engineer****

****You also need to provide the following information:**

Gas Composition	We calibrate our mass Flowmeters to NIST standards with actual gas or a mixture that reflects the end user's process. Please provide the exact gas name or gas mixture with each gas listed as a percent of the total, with the sum equaling 100%
Full Scale Flow	Please provide your maximum and minimum flow rates; units must be Kg/hr, Lb/hr, NCMH or SCFM.
Line Size	Please specify your pipe size as well connection type (flange, threaded, etc..)
Gas Pressure and Temperature	We will calibrate under conditions as close to your process environment as possible
Electronics Temperature	Ambient temperature of the environment surrounding the flowmeter's electronics.
Power Requirements	Please specify your power requirements, such as 24 V _{DC} or 115 V _{AC} or 230 V _{AC}
Configuration	Various configurations such as Ex proof, Non-Ex proof, remote, and integral are available. Please see below:

➤ Model Selection Guide

ATMF9000 Series												
Example ATMF9716-SSS-133--AC220-FSW1500-CR1-CONF-Natural Gas (2,000 NCMH, 70C,7 Barg)												
AMF9-	X	XX	XXXX	XXX	133	XX"	XXXX	XXXXXX	XXX	XXXX	Gas type, Flow rate,P,T,Pipe size	Description
Remote	1											Style
Integral	7											
2"	16	0-2500 NCMH										Flow body - Diameter and Flow Ranges
2½"	20	0-3500 NCMH										
3"	24	0-5100 NCMH										
4"	32	0-9200 NCMH										
6"	48	0-20500 NCMH										
Explosion Proof	MP											Environment
Non Hazardous	MPNH											
316 SS < 160 °F (70 °C)	SSS											Material (316 SS)
Display- Included	133											Display
115 V _{AC}	AC115											Power Supply
230 V _{AC}	AC230											
24 V _{DC}	DC24											
NPT	NPT											Connections
DIN	DNFL											
JIS	JIS											
ANSI 150# -Included	FSW1500											
ANSI 3000#	FSW3000											
ANSI 600#	FSW6000											
One calibration curve	C1R											Output curves
Two calibration curves	C2R											
Three calibration curves	C3R											
Four calibration Curves	C4R											
Extended temperature electronics → -40 - 185 °F (-40 to 85 °C)	ETEMP											Options
Calibration and test point report	CONF											
Process Gas (Please indicate, gas type, flow rate, line size, pressure and temperature)												Process Data
For larger flange sizes, other materials of construction (Hasteloy C, Monel), please contact SMC.												