



GENERAL

ALHPD Positive Displacement Helical Flow Meters

Two highly accurate cycloid-shaped screw spindles mesh and rotate inside a cylindrical housing with two overlapping holes in the form of a figure 8, which forms the measuring chamber. Liquid flows in axial direction and rotates the spindles, it is forced along the measuring chamber bores by the profile of the spindles. This happens without pulsation and with minimum leakage. A pickup will inductively detect the speed of the spindle pair through the housing via a pole wheel with a high number of gears. The speed of the spindles is absolutely proportional to the volume flow over a very wide range. Pulses per volume unit will finally serve the evaluation (in addition an analogue signal 4 to 20 mA will be available when using the local display unit ALVTM). The K-factor (calibration factor) of the helical flow meter defines the exact pulse rate per liter. We calibrate our flow meters to match the customer's operating viscosity to determine their Kfactors.

ALVTM Display with Frequency and Analog Output

The ALVTM is a programmable local display with integral carrier-frequency pickup and amplifier for Alia turbine meters. Flow rate is indicated in an 8 digit LCD display with 14 segments. A 10 point linearization is included to optimize the accuracy. The pulse output provides a flow-proportional frequency signal or scaled volume pulse in accordance with programming. For electrical connection a 6-pin plug or a junction box with 6 internal terminals is provided.

FEATURES

- High accuracy and Wide measuring ranges 1:100, 1:400
- Suitable for pressures up to 400 bar
- Low pressure drop compared with other positive displacement meters
- Double pulse rate and reverse-flow detection possible
- Pulsation-free measurement, non-sensitive to pulsating flows
- Resistant to corrosion by advanced materials and bearings
- Low operating noise
- Ex-protection EExialICT6 for zone 1

SPECIFICATION

ALHPD- Helical Flow Meters

- Process Connection : 1/4"-1 1/2" FNPT
- Operating pressure : PN 16/40 up to PN 400
- Process temperature : up to +150°C (higher T up on request)
- Flow rates : 0.01 to 400 LPM
- Viscosities : 30 up to 1 x 10⁶ mm²/s (below 30 mm²/s with restricted measuring range and vertical mounting)
- Material : SS DIN 1.4571/1.4435 (SS316 Ti/316L)
- Linearity : ±0.50% of actual flow value (from 30 mm²/s up) ±0.25% of actual flow value (from 100 mm²/s up)
- Repeatability : ±0.10%
- Weight : Flowmeters : 2.5 to 35 kg
Electronics : 0.25 kg to 2.5 kg

ALVTE Carrier Frequency Pulse Amplifier

- Supply Voltage UB : +8.5 up to 29 VDC, controlled (incl. reverse-battery protection)
- Quiescent current : < 5 mA
- Frequency range : 2 up to 4,000 Hz
- Process temperature : 120 °C with a distance of at least 25 mm between flow meter and electronic housing 150°C at least 65mm



ALVTM Electronics

- LCD display : 8 digits (14 segments), digit height 7mm for real-time value, totals and programmable
- Linearization : with 10 points
- Process temperature : -40 ~ +120 °C with a distance of at least 25 mm between flow meter and electronic housing
- Ambient temperature : -40 up to +70 °C
- Weight : 700 g
- Frequency output/divider : 3-wire, 8-30VDC controlled, Ex-versions: <25 mA, 12-30 VDC
- Signal output : push/pull, I_{max}: 20 mA,
- Frequency output, f_{max}: 3,000 Hz, duty cycle: approx. 1:1, 2.divider, pulse.width: 1 ms, 20 ms, 50 ms, f_{max}: 500 Hz
- Analog output : 2-wire (4-20mA)
- Supply voltage : 14-30 V DC controlled, UB = (R_{load} x 20 mA) + 14 V
- Load : < 800 ohms
- Time constant : < 0.2-3 s (programmable)
- Resolution : 12 bit (3,9uA)
- Housing : IP 65, aluminum AlMgSiPb, blue anodized
- Ex-protection : II 2 G EEx ia IIC T4, BVS 03 ATEX E 205

Pressure Drop Diagram

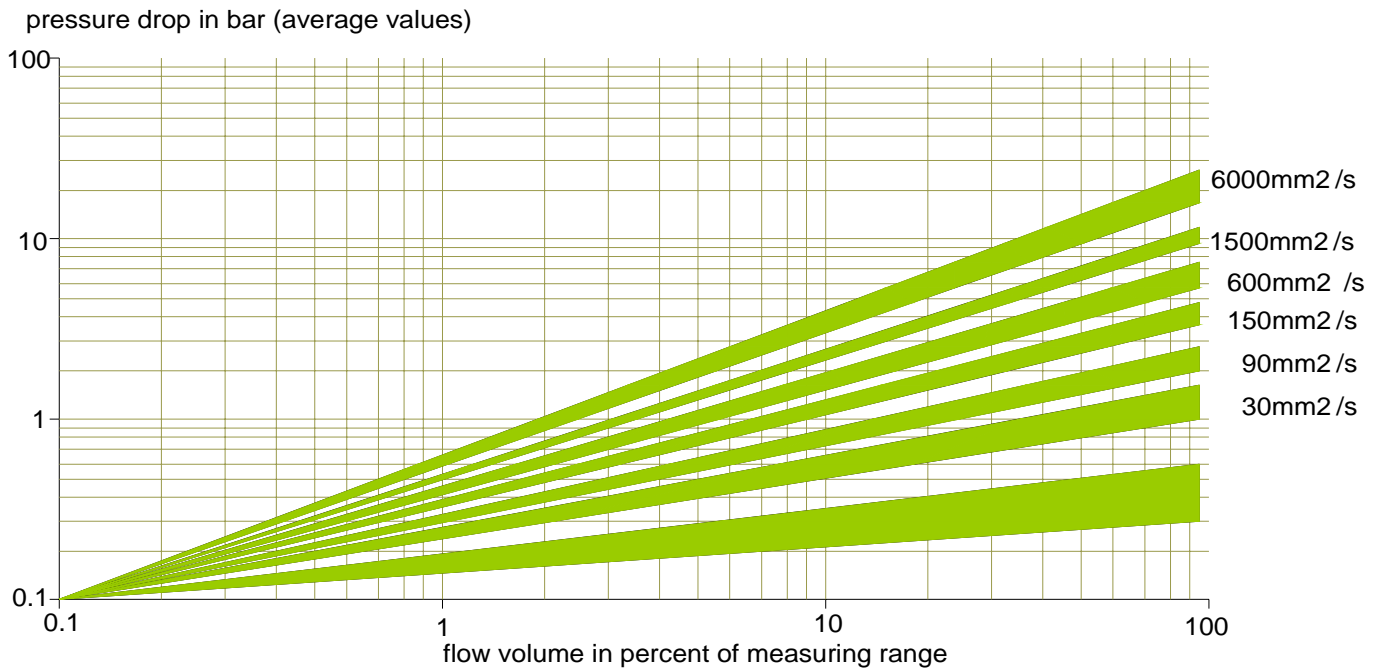

K- Factor for Positive Displacement Helical Flow Meters

Type	Flow (LPM)	K-factor (pulses/l)	Frequency range in Hz.	
			Min	Max
ALHPD				
HPD 10	0.04 to 0.4 and 0.4 to 4	16500	3	1000
HPD 20	0.16 to 1.6 and 1.6 to 16	9000	6	1250
HPD 40	0.4 to 4.0 and 4.0 to 40	3500	20	1740
HPD 100	1.0 to 10.0 and 10.0 to 100	850	8	1750
HPD 4000	4.0 to 40.0 and 40.0 to 400	214	14	1800

Cross Section Drawings

HPD10

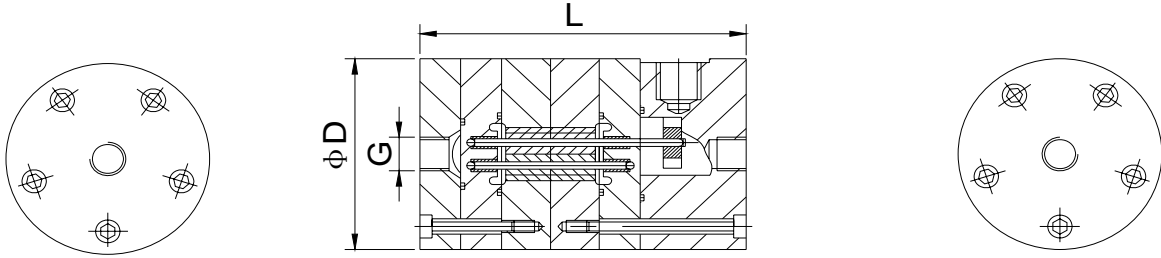

HPD20

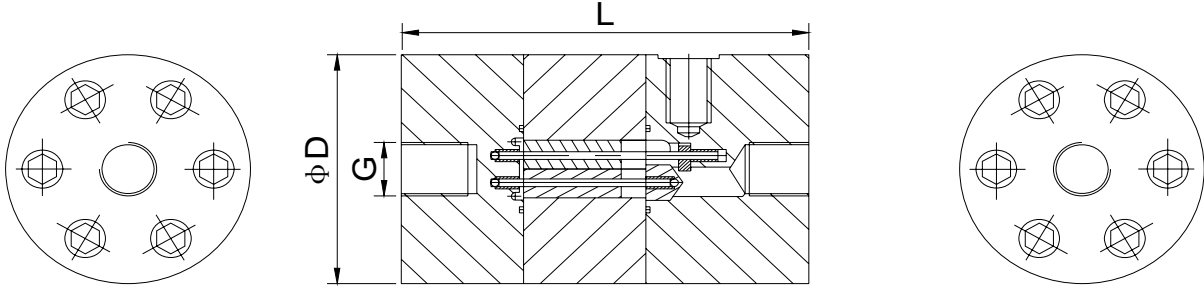

HPD40/HPD100/HPD400

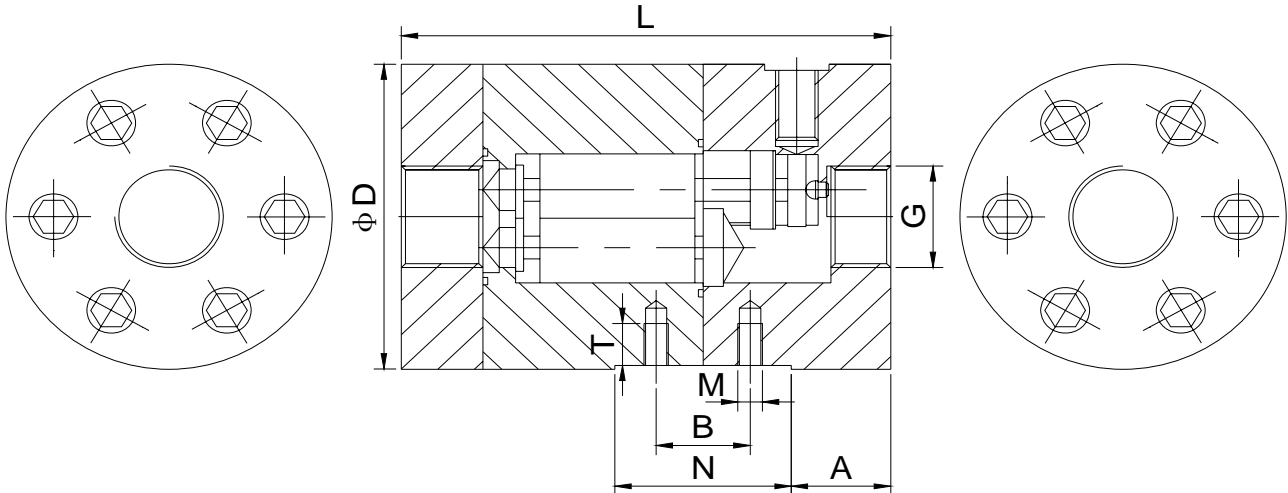

Dimensions

Type	G	L	D	PN
HPD10	1/4"	110mm	60mm	400bar
HPD20	1/2"	125mm	76mm	400bar
HPD40	3/4"	155mm	85mm	400bar
HPD100	1"	221mm	110mm	400bar
HPD400	1 1/2"	318mm	134mm	400bar

Fixing holes(only HPD40 and 100)

Type	M	T	B	N	A
HPD40	M8	12.0mm	25.4mm	52.0mm	36.5mm
HPD100	M10	18.0mm	44.0mm	66.0mm	54.0mm

**** Please contact your local SMC application engineer**

You also need to provide the following information:

Type of liquid	We need the name of your liquid, including operating density and viscosity
Full Scale Flow	We need your maximum and minimum flow rates, units must be Kg/hr, Lb/hr, LPM or gpm, etc..
Line Size	we need to know your pipe size as well connection type (flange, threaded, etc..)
Process Pressure and Temperature	We calibration your flowmeter as close to your application as possible
Pressure drop	Indicated the maximum pressure drop (see pressure drop graph) that your process can withstand
Type of Electronics	Indicate if you want integral, remote panel or remote wall mounted
Power Requirements	Specify your power requirements such as 24 VDC or 115 VAC or 230 VAC

➤ Model Selection Guide

ALHPD Series					
Example ALHPD-100-ST-ALVTMB-F-EX					
ALHPD Series	***				Description
1/4 inch	10	0.04 to 0.4 and 0.4 to 4			Sizes and Flow rates (LPM)
1/2 inch	20	0.16 to 1.6 and 1.6 to 16			
3/4 inch	40	0.4 to 4.0 and 4.0 to 40			
1 inch	100	1.0 to 10.0 and 10.0 to 100			
1 1/2 inch	400	4.0 to 40.0 and 40.0 to 400			
Hard metal bearing	ST				Bearings
ball bearing	KL				
Compact with integral dual pickup	C				Only available from 3/4 to 1 1/2" size
Electronic Options - IF no electronics leave parts below blank (part number for electronics depends on ALVTMB,ALVTE or ALIF)					
Electronics - ALVTM (programmable display) series					
Frequency/divider and analog	ALVTMB				Analog outputs
Top View	D				Display
Standard with window	NX				Protection
Ex proof with window	EX				
Electronics - ALVTE Carrier Frequency Pulse Amplifier					
Carrier-Frequency pickup	ALVTE				frequency range 2-4000 Hz
Standard	NX				Protection
Ex proof	EX				
Short thread 110 mm	EK				Thread size
Long thread 149 mm	EL				
Electronics - ALIF-Inductive Pickups and Pulse Amplifiers (for -12 to 180C)					
Frequency pulse amplifier	ALIF				
Standard	NX				Protection (II 2 G EEx ia IIC T6)
Ex proof	EX				